

Audio, Video and
Communications
for Broadcasters



OLYMPIA 3

AoIP Networked Commentary Unit



AEQ has been an equipment and service provider to the different Host Broadcasting Organisations for very large sport events since the Seoul 1988 Olympics.

1998

Our first Digital Commentary System – DCS-10 saw the light in 1998, and was used for the first time at the Nagano Winter Games. Since then, the system has been used very intensely on all continents to provide first class service to the worlds broadcasting community.



2010

The second-generation, OLYMPIA Digital Commentary System, was the successor to the DCS-10 system and has the required capacity to service the largest broadcasting events in the World. It was used for the first time to provide the Unilateral Commentary Signals for the Vancouver 2010 Winter Games, growing to over 1200 commentary positions at the London 2012 and Rio 2016 Games. The system is still servicing a myriad of customers, including fixed infrastructures at world class sports venues and stadiums all over the world.



Now, taking advantage of all these years of experience, (see references at: <http://www.aeq.eu/aeq-today/events>) and taking advantage of our know-how in Intercom systems and their use in Outside Broadcasting Units, we now proudly present the new Olympia 3, Digital Commentary System with AoIP Multi-Channel Audio Network Connectivity.

Now we present

OLYMPIA 3

with these outstanding features:

- Standalone commentary unit (CU), or AoIP connected with 8 channels via Dante™ protocol. Scalable architecture: simple routing to Dante™ IP devices; integrated in IP intercom system, or connected to IP commentary system matrix.
- Standalone mono or stereo sound mixer with mixing, routing, tone and dynamics control. 3 commentator inputs and a dual-mono or stereo line level input. Monitoring of 8 remote and 2 local sources.
- Operates as an intercom panel at the same time as a Commentary Unit.
- Configurable as an interpreter/simultaneous translation console for up to three languages.
- Three Gb IP ports per unit for redundancy, daisy chain and auxiliary data or video transport.
- Transport of IP Video and Video Program Source Selection for the Commentary Position
- Dual power supply: 48VDC via PoE or external local power supply.
- Software Configuration and remote control.
- Rugged and ergonomic mechanics, suitable for indoor and outdoor locations.





OLYMPIA 3



Operates as an Intercom User Panel and as a Commentary Unit in a Commentary System

Olympia 3 represents a breakthrough in Commentary Systems, providing greater flexibility and adaptability to different event sizes. This way, Olympia 3 has been designed to suit large events with hundreds of commentary positions at the same venue, as well as more modest installations where it may operate as a stand-alone unit or in an OB Van linked to an AoIP Intercom System. Apart from being a Commentary Unit, it can be used simultaneously as an Intercom User Panel, or momentarily, for example, during system set-up phase.

The OLYMPIA 3 can be operated in a hybrid mode, having two simultaneous functions:

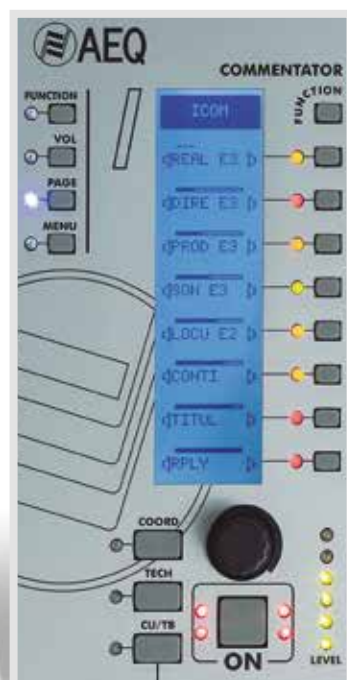

An Intercom User Panel:

For this mode, the channel "COMMENTATOR 1" includes the required functionality and signaling to be able to operate as an Intercom channel. When operating as an Intercom Panel it provides the same level of functionality as the KROMA by AEQ Series 8000 User Panels. Commentator 1 channel assumes the functions of an Intercom Panel. The display corresponding to channel 1 will adopt the "Intercom Mode" and the keys will adopt the programmed intercom destinations or functions and the associate microphone and headphone will form part of the Intercom System.

A Commentary Unit (CU):

The OLYMPIA 3 CU CONTROL application configures and controls the CU except the circuit that Commentator 1 is using as its intercom circuit and when operating in this Intercom mode.

Each commentator can monitor the audio sources as required and a common Video program source can be selected for the Commentary position.



STANDALONE OR CONNECTED TO SMALL, MEDIUM OR LARGE SYSTEMS

Olympia 3 is a standalone sound mixer. That is why it can operate as an independent or standalone Commentary Unit or linked to a small, medium or large Commentary System.

OLYMPIA 3 CAN BE OPERATED IN FOUR DIFFERENT WAYS:

As a Standalone CU

Simply controlled from its front panel, and if so required, complemented by a PC running the Olympia 3 CU CONTROL software application.

Connected to an AoIP multi-channel network and routing system.

That is, receiving and sending audio from/to any Dante™/AES67 system, that can be anything such as a mixing console or NetBox audio interface produced by AEQ, a third-party console installed in a mobile unit, or any other type of device manufactured by any of the many manufacturers that are incorporating Dante™, or even using AES67 protocol.

Connected to a KROMA by AEQ AoIP Intercom System

Olympia 3, apart from being a Commentary Unit, can also be used as an Intercom User Panel. It can be connected this way to any AoIP Intercom manufactured by KROMA by AEQ. This way, the ConeXia, or CrossNET matrices will route incoming and outgoing audio to/from the unit and, at the same time, Channel 1 of the Commentary Unit can operate as an Intercom System User Panel. This application becomes very useful where the unit is part of an OB Unit and where the Intercom System also acts as a routing matrix for commentary audio.

Connected to a Commentary System

The extraordinary capacities of the Olympia system, used for large multi-sport and multi-venue games, and the smaller "classic" Olympia, used in mid and large sized sports events has been incorporated to Olympia 3. The centralized control of the entire system for audio transport and distribution, System for event planning, redundancy, management and supervision features of the Olympia system are also available.

IP INTERFACES

Olympia 3 is an AoIP transmission device for Commentary Systems. It includes an internal switch with 3 external ports, allowing for redundancy, "Daisy Chain" connection, as well as making it possible to use the Commentary System IP infrastructure for auxiliary data or video transport for the use at the Commentary Position.

Olympia 3 features an AoIP audio interface with eight input and eight output channels. This is the maximum available connection capability with the rest of devices within a Commentary or Intercom System deployment.

On many occasions, this number of inputs and outputs is quite probably more than the actual needs, whereas the overall capacity of the Matrix or Audio Interface System can be optimized for the operational needs.

LOCAL PROCESSING

Olympia 3 isn't simply a remote audio interface with monitoring control for an audio mixing and processing system.

It features local audio processing, enabling it to be used as a standalone sound mixer with routing functions, filtering, tone and dynamics control, without requiring connection to an external routing and processing system.

POWER SUPPLY

Olympia 3 can be powered in two ways: with a local power supply, and at the same time it can take power from a PoE+ (Power over Ethernet) port that receives the necessary power from the IP PoE switch that it is connected to.

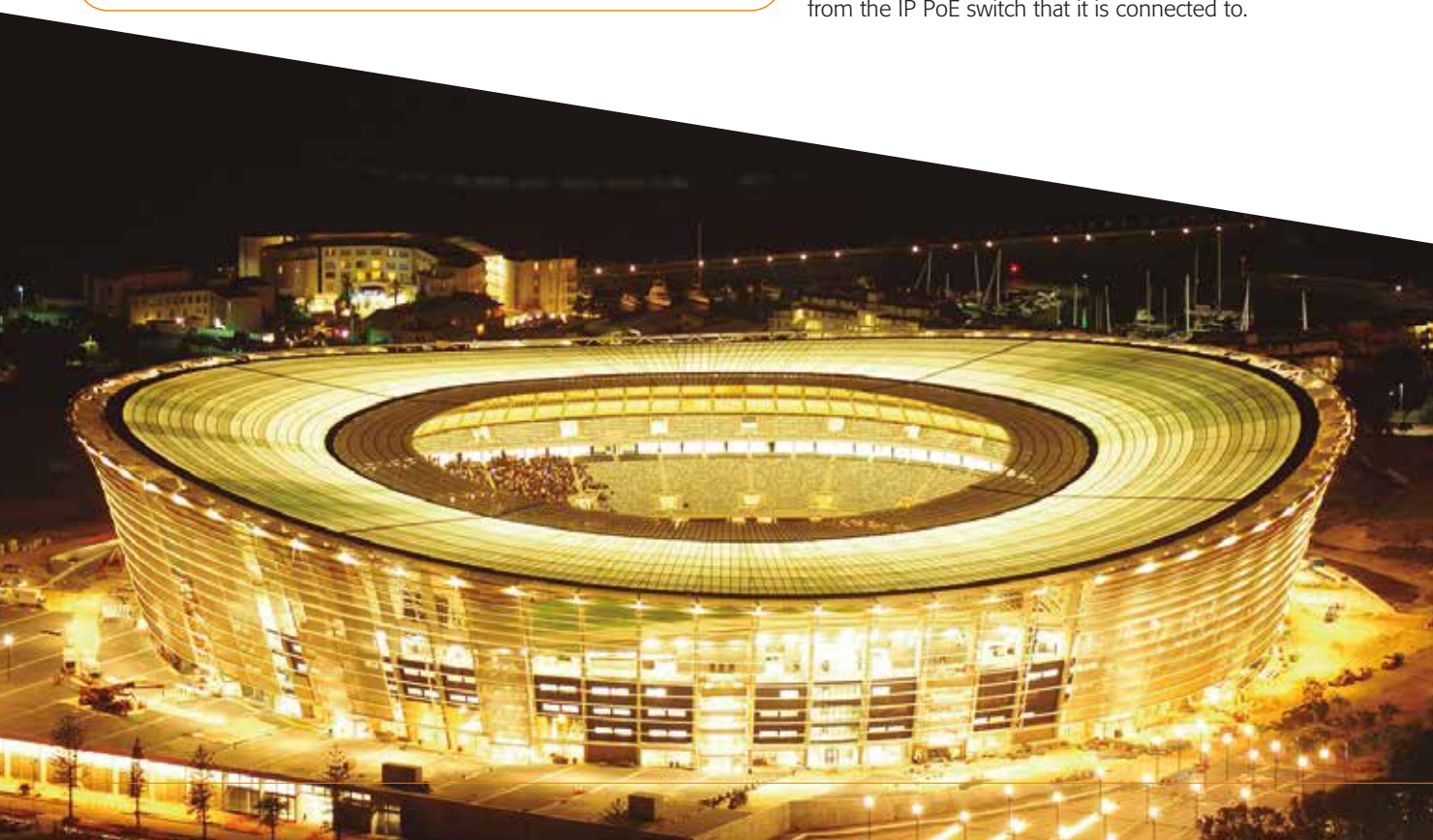



Local I/O configuration and local matrix dimension

One headphone output is provided for each commentator, consequently, a total of three stereo or dual-mono outputs.

There is also an auxiliary output that can be used as stereo or as two independent auxiliary mono channels.

System local inputs are: a microphone for each commentator, an auxiliary input that can be used as stereo or as two independent mono inputs, and several internal inputs: local oscillator signal, two line identifiers, replay of the last intercom-message, intercom ring-tone and two unassigned but programmable as per requirement.

This makes up an internal local matrix with 20 inputs and 16 outputs, including the 8 inputs and output from/to the Dante™ network.

Local Outputs, 8:

- HP1 ST / 2 Dual Mono.
- HP2 ST / 2 Dual Mono.
- HP3 ST / 2 Dual Mono.
- AUX OUT ST / 2 AUX OUT Mono.

Local Inputs, 12:

- MIC 1.
- MIC 2.
- MIC 3.
- Aux IN ST / 2 AUX IN Mono.
- Local signal generator.
- 4 line ID.
- Replay from Intercom.
- Intercom call alert tone.

AoIP Network I/O's:

- 8 AoIP inputs and 8 AoIP outputs.



OLYMPIA 3 MIXER AND LOCAL ROUTER DIAGRAM

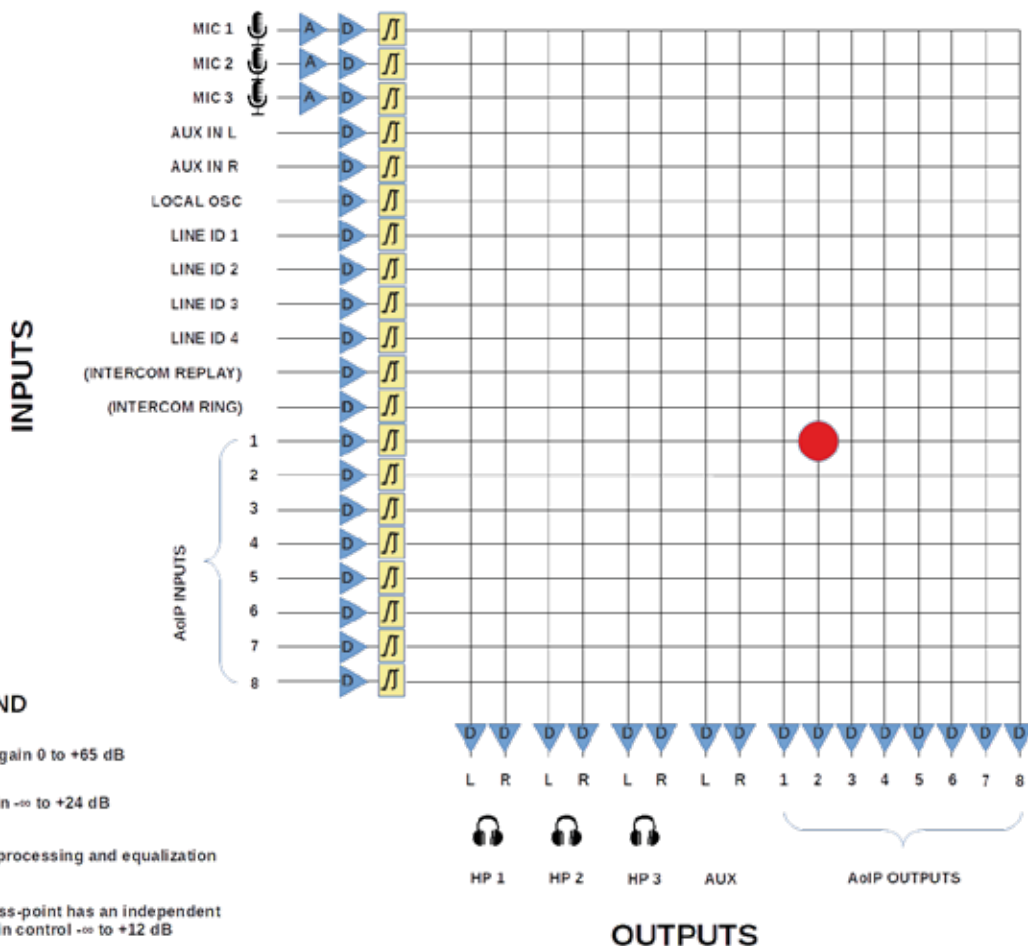

OLYMPIA 3 uses Dante™ -based audio over IP links to communicate

Maximum capacity is eight input and eight output channels, but not all of them need to be used, so the dimensioning of the system's resources for signal reception and transmission (let them be matrixes or simple Dante™ interfaces) can be adjusted to the exact requirements.

Usually, a main program is sent, and that can be mixed locally with stereo international sound, and sometimes with auxiliary input sound.

Whenever required, it can be used as a stereo Commentary Unit, mixing local microphones with stereo international sound and an additional input that also can be configured as stereo.

In large systems, audio is usually processed and mixed within the matrix. For these cases, each individual commentator audio can be sent as separate channels.

Return or monitoring signals required by the commentators will be received from the Dante™ network.

Additionally, a bidirectional communication will be established whenever an intercom connection is made through channel 1 intercom panel with technicians, studio or any other destination.

Configuration of the AoIP Network inputs and outputs

The 8 Dante™ AoIP audio channels can be configured in a flexible way allowing to assign them as:

- TX: Main Program as local Mono or Stereo mix and mixed with the Stereo International Sound.
- TX: Each Talent/Commentator can be sent as individual and separate audio channels.
- RX: All required audio returns and IFB's.
- Tx / RX: Two-way Intercom circuit with Technician, Studio and selectable as an Intercom User Panel.

DANTE™ AoIP Multichannel Network I/O's

The eight outputs will typically be assigned as: three commentator microphones, local mix (that may be stereo), CU/T'back circuit towards other linked CUs, technical coordination with CU controller using OLYMPIA 3 CU CONTROL software, and coordination with remote studio. Channel 1 Technical coordination circuit will also be a coordination output when operating in intercom mode.

Typical assignment for the eight inputs, coming from the Dante™ network, is as follows: a pair for international sound (either two IS channels or stereo), mono signal from venue PA system, guide signal from another commentator, CU/T'back from other linked CUs (voided when working in Intercom mode, becoming the Intercom input), auxiliary mono, technical coordination to each commentator, and studio common coordination signal to all commentators.

In any case, this is a very flexible system that can be configured to any need:

"Programs" can be set up (these are up to 10 audios sent by the CU), defining how many of them are mono and how many are paired in stereo, as well as what CU physical channels are used to send them (either local or Dante™ remote circuits), mixed inputs (as many as required, and not only IS), and whether the program is "normal", dedicated to coordination or talkback (each program behavior will vary accordingly).

Configuration of the typical AoIP Network inputs and outputs

Typical Outputs and Inputs for the DANTE™ Interface:

8 Outputs:

- COM 1, COM 2, COM 3. COM 1 is also the COORD output in Intercom Mode.
- Local Stereo (or Mono) Mix.
- CU / T'Back to Linked CU's.
- Coord TECH with CCU (Commentary Control Unit). Coord Tech can be configured as an Intercom with other destinations.
- COORD Studio with remote Studio.

8 Inputs:

- One IS Channel: IS1, IS 2 (or IS1 in Stereo).
- PA mono.
- Guide.
- CU /T'Back to Linked CU's. This is cancelled when in Intercom Mode and converted into an intercom Input.
- AUX mono.
- Coord TECH CCU with each talent/commentator (selected through the remote activation of the local matrix of the CU).
- COORD Studio to commentators (Preselected).

There are three Gigabit Ethernet connectors at the back panel, all of them connected to the internal device switch. They are not exactly identical functionally: the ruggedized and lockable one includes PoE+ power supply input, while the other two are identical, and one of them can be used to form a Daisy Chain or for redundancy, while the other is available for auxiliary output to a local PC or the optional VIDEOLINK 4K streaming video decoder.

There is also a connector for local 48 VDC power supply input.

There are three local microphone inputs, one for each commentator.

They feature selectable Phantom supply, and one of them can operate as an intercom panel microphone.

When microphone 1 is operating as an Intercom input, its associated headphone will also receive the Intercom signal.

Besides, there is a stereo or dual-mono line-level input.

Local audio outputs include the three headphones associated to each microphone input (that may operate as stereo or dual-mono). Signals listened into each one can be chosen. There is also a stereo or dual-mono line-level output.



REAR

To the left are located the XLR connectors for the electronically balanced analog line inputs and outputs. They have mute and gain control.

Line level regulation range +12 / -30 dB, individually or linked.

Observe the switch with 3 external ports, a PoE with ruggedized and lockable connector, and the local power connector.



FRONT

Three electronically balanced high quality microphone inputs with software selectable 48V Phantom Power and three Stereo or Dual Mono Headphone outputs.



Cabling

A difference to previous systems where each CU required a cable to a control card within the matrix frame, in Olympia 3 audio uses Dante™ AoIP protocol, sharing an Ethernet network.

The use of PoE+ capable switches is recommended, so wiring is simplified and additional connections for power supply are not required.

The unit has a built-in switch with three ports accessible through connectors. One of these is a powered PoE+ Port. Alternatively, each CU can be powered locally and data is connected through a daisy chain and since each unit has an internal IP Switch.

The three ports are 100 Mbps/1 Gbps.

When cable runs between the switch concentrating commentary positions and the OB van or CCR (Commentary Control Room, the place where the control PC and Commentary Control Unit applications reside) are greater than 100m, the use of switches featuring fiber optic link connection is recommended, as they allow for longer distance hops.

CU Ethernet wiring also allows for distribution of data or video from CCR or OB van to the commentators.

The video program source to be displayed on the Commentary Position video monitor, is selected through the designated keys corresponding to Commentator number 3 on the Commentary Unit, i.e. this will convert into a pre-selector keypad for the corresponding VIDEOLINK 4K decoder.

3 DIFFERENT WAYS OF CABLING THE OLYMPIA 3 COMMENTARY UNIT

- Data and power connected through a PoE+ Network Switch.
- Data is connected to a standard Network Switch and the unit is powered locally from the electrical grid.
- Data is connected in Daisy Chain and the unit is powered locally from the electrical grid.

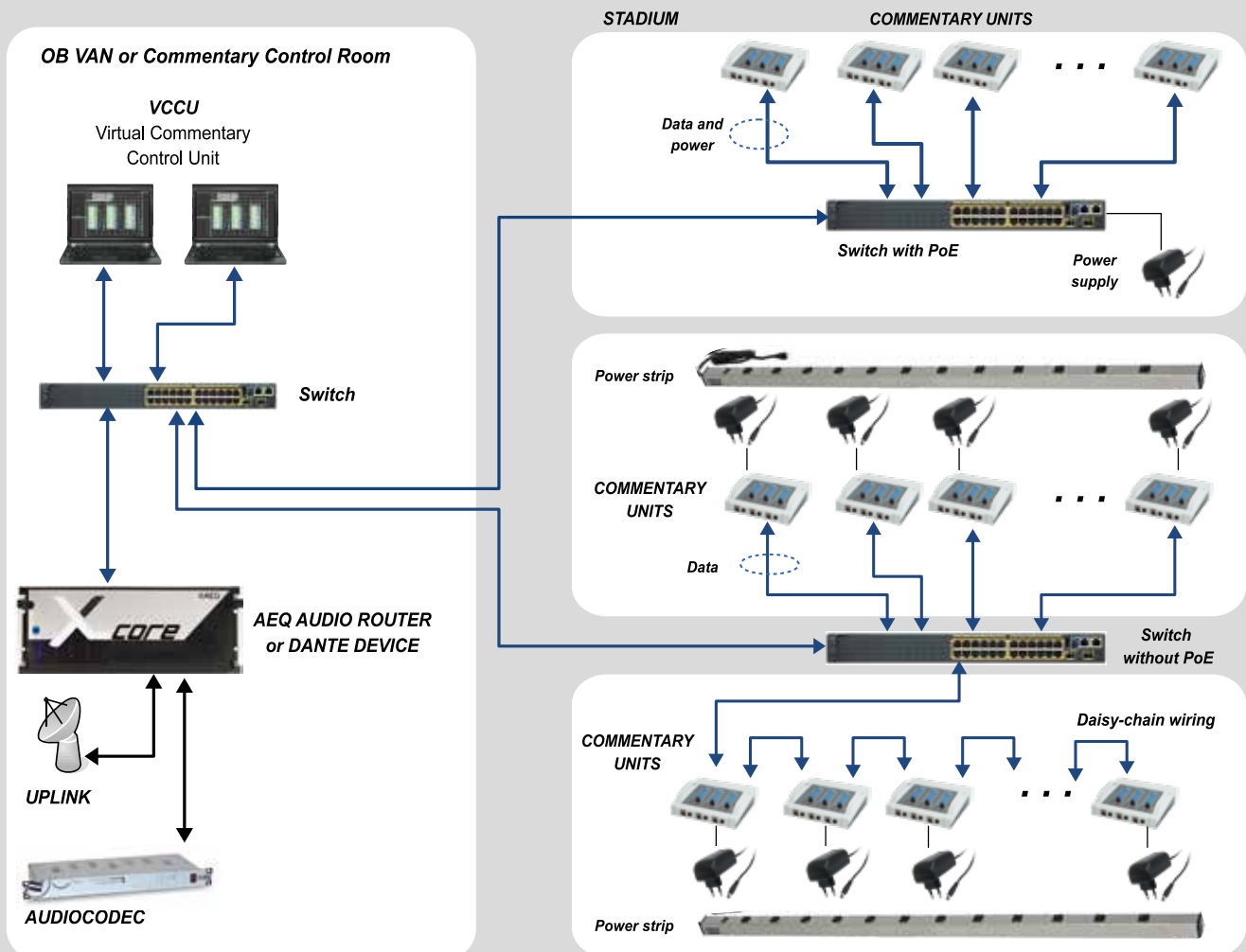

Control Surface

Each channel has an associated display with nine keys at its right, and a dynamic label associated to each of these keys.

The first key from the top is dedicated to functions selection, which puts the channel in Configuration or Feedback modes, alternatively. For Commentator 1 channel only, a third "Intercom" mode is available. For the channel corresponding to Commentator 3 only, a third "Video" mode is available.

The other eight keys are associated to dynamic labels, appearing in the screen. When in "Feedback" mode, these labels indicate which signals are routed to left, right or both ears.

In "Configuration" mode, authorized users may adjust some parameters defined by the manager.

Last, in "Intercom" mode, each key will be associated to an intercom user or group. The same rules apply than in all KROMA by AEQ Intercom Systems.

The encoder that each channel has located under the display adjusts listening level, and in special situations it allows for the selection of some options.

An outgoing level indicator is available at the lower right area of each channel for user's reference. Also in that area, you can find the ON key at the center, to open or close the channel. At its left, you can find CCORD, TECH and CU/TB keys, for communication with the commentary system specific destinations.

Four generic intercom system keys are located at the left of the panel. These are used in just the same way as in any KROMA by AEQ Series 8000 Intercom panel.



Reliability and visibility

Our extensive experience at this kind of events led us to render the Olympia 3 with excellent ergonomics and mechanics. Such features are paramount for demanding operations and in adverse climate and environmental conditions: cold, heat, with slight rain, under direct sunlight or almost darkness.

In the event of a network, power-failure or the unlikely event of a malfunctioning CU requiring replacment, the boot time for the OLYMPIA 3 is under 7 seconds. This becomes paramount at live operations, reducing the "Off-Air" time and mitigating their consequences.

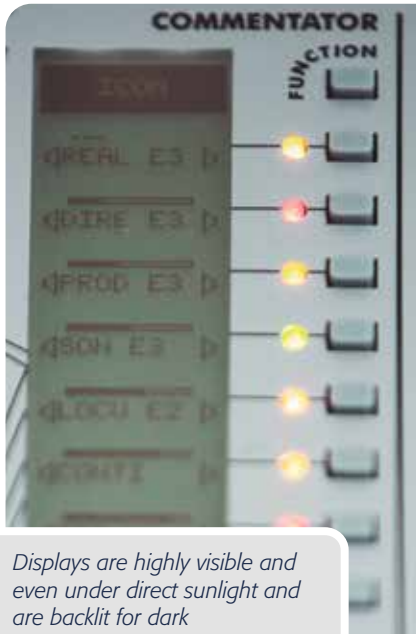

Displays are highly visible and even under direct sunlight and are backlit for dark environments. The LED's have adjustment for the intensity so that they can be dimmed for interiors and bright for exteriors and visible under direct sunlight



Splash-proof construction, with silicone gasket that covers or embraces the elements of the front panel

The metal chassis is finished with an ABS cover in light colour reflecting heat received from, for example direct sunlight. The cover is very impact and scratch resistant. Tiny scratches or dents are barely visible since the ABS is injected in the colour of the surface. The handles are a great help when packing and transporting and are also protecting the work surface. The black chassis helps in dissipating the internal heat.

SPECIFICATIONS:

- White anti-shock ABS case that closes a lower and rear metal frame. Dimensions: 280 x 200 x 80 mm. (Approximately).
- Exterior Resistant: Splash-proof construction, with silicone gasket that covers or enfolds the front panel elements. Designed to work in adversethermal conditions.
- Ventilation. In low temperature situation, totally silent natural convection. At high temperature starts a fan of low acoustic emission.
- Superior surface with a clear tone to avoid heat from outside.
- Black bottom and back frame to radiate internal heat.
- Displays, LEDs and Vu-meters visible with direct sun. There is a low brightness setting for use in dark interiors.





Standalone audio mixer with internal routing, tone and dynamics control

We want to highlight the ability of Olympia 3 CU to operate as a stand-alone sound mixing console, able to mix microphones, international sound and external inputs with tone and dynamics control.

Each commentator has eight keys for monitoring selection that can be labeled (up to 8 characters) and indicators to show whether they are monitored on left, right or both ears. An authorized user will be able to adjust his channel general listening level and the relative gain for each individual source.

The ability to have a stereo program output when required, simplifies the mix of commentator voices into a program that is built on the stereo international sound.

Output level for each of the three microphones, auxiliary input, international sound and global mix can be adjusted by software.

If required, Olympia 3 can send the flat audio of each microphone input to a complex commentary system such as Olympia for its final processing.

An important feature of the Olympia 3 CU's sound mixer is individual dynamics control for each microphone.

Another outstanding feature you can find in Olympia 3 CU is the availability of individual, software-controlled, tone control with pre-sets for each microphone channel.

Audio routing and mix for program send can also be distributed to the local line output in mono or stereo format.

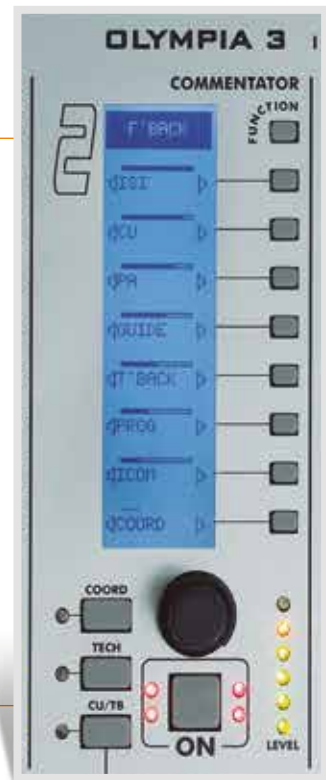

Operating as an Audio Mixer

- 8 keys for monitoring return selection and associated LCD display.
- 8 characters per line.
- Sending of each individual source L, R, L+R and local gain control.

Freestanding sound mixer with routing, audio, tone control and dynamics. Up to 16 configurable outputs as: stereo or mono, mixing or isolating the microphone outputs, IS, auxiliary inputs, identifiers, oscillator, etc. Levels adjustable by software.

Dynamic control (DLP: compressor and limiter), and noise gate. Configurable by software.

Individual tone control for microphones; three-band parametric EQ. Frequency filtering: high pass, low pass and band pass. Configurable by Software.

Program outputs can be routed to any local output (line or headphones) or to the IP network.

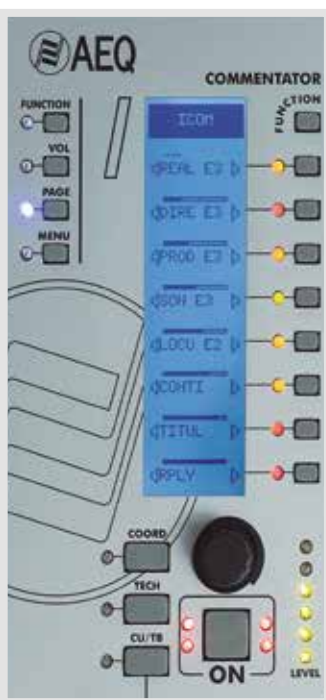

Operating as an Intercom User Panel

Olympia 3 CU channel 1 can also operate as an Intercom user panel with the same features as a KROMA by AEQ Series 8000 User Panel. This saves installing an Intercom user panel next to a commentator position at small events.

Each of the commentators will have the possibility that in their TECH channel other interlocutors can be defined within the Intercom System. To avoid being distracted when commenting, the intercom monitoring must be properly routed.

To generate calls, the user of channel 1 can put his LCD in "Intercom Mode" pressing the FUNCTION Key until the "labels" of the Intercom User Panel appears.

It has 8 keys and associate labels with up to 8 characters.

Configurable within KROMA by AEQ Crossmapper software.



Video Link



VideoLink 4K is a system for transporting IP Video to the Commentary Positions in an Olympia Commentary System

Each video signal is ingested in HDMI format to a VideoLink 4K ENCODER, that in turn will convert the signal and place it on the IP network. This way, all the different Video Sources ingested will be available and distributed on the same network as the Multi-channel AoIP is using to transport both common (Multilateral) and individual (Unilateral) audio signals from the different production areas of the Venue. This way these Video Sources will also be available at the Network Switches associated to the Commentary Positions and their Olympia 3 Commentary Units. By simply connecting the Video Link 4K DECODER to the ancillary data Ethernet port of the Olympia 3, the Video sources will be available on the HDMI Output ports of the Video Link 4K DECODER and can be connected to the HDMI Input of the Commentary Position's Video Monitor.

The video program source to be displayed on the Commentary Position video monitor, is selected through the designated keys corresponding to Commentator number 3 on the Commentary Unit. I.e., this will convert into a pre-selector keypad for the corresponding VIDEOLINK 4K decoder. Alternatively, the Video Sources to be displayed can be controlled from the Virtual CCU application.

The video signal is converted into IP packages suitable for network transmission, which is compatible with commercially available IGMP-enabled Gigabit Ethernet (GbE) switches (Jumbo Frames enabled). Using the Cat5e / 6 cabling infrastructure necessary for commentary positions, users can connect Cat5e / 6 cabling to any decoder anywhere on the same GbE network.

The Olympia 3 keypad supports selecting one of 8 different video sources. The signal can be sent in 4K UHD mode, occupying a bandwidth of 50 Mb / s, providing excellent quality and with full compatibility with audio in Dante or AES67 format. It can also be sent in other resolutions or qualities, (adjustable bit rate from 10 to 200 Mb / s). A good, alternative option is to use FHD monitors, with a 12 Mb/s bit rate per channel. The number of possible receivers is unlimited, since video transmission is done in multicast mode. The monitors receive the signal through the HDMI 2.0 interface



Video 4K Encoder-Decoder Diagram

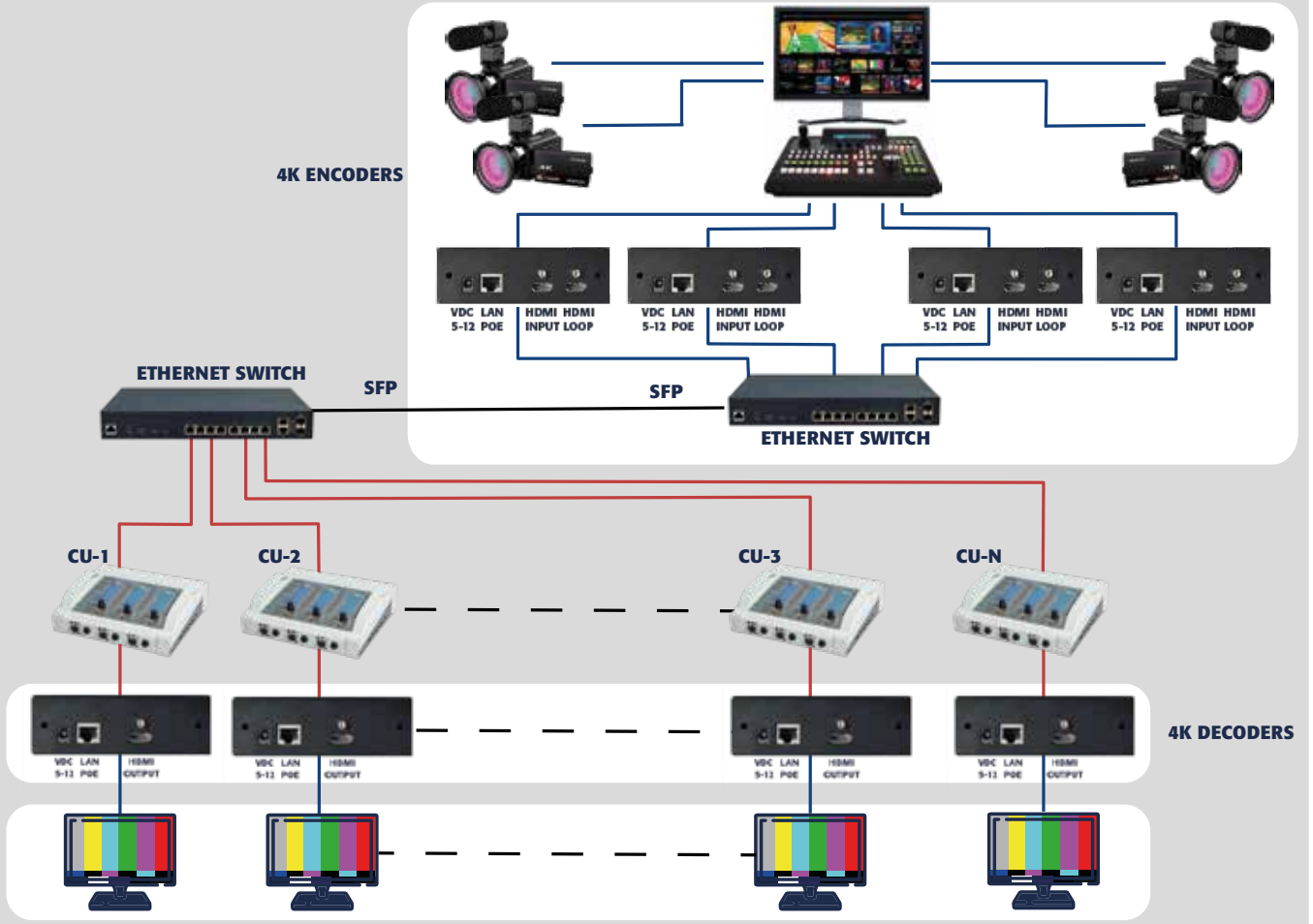

Patch Panels

Video Link 4K ENCODER



Inferior Panel

Superior Panel

Video Link 4K DECODER



Inferior Panel

Superior Panel

SPECIFICATIONS:

Standards:

Power over Ethernet Port - PoE+, UTP/STP 1000Mbps Ethernet port (8K Jumbo Frame required)
 Protocols: IP, UDP, TCP, ICMP, IGMP
 HDMI port 19 pin type A female
 PoE Power. DC 5V, 2A alternative power
 Max. Timing supported 2160p @ 60fps
 Latency ~ 1 frame, ~ 17 ms at 60 fps, ~ 33 ms at 30 fps
 HDMI 3D Support: HDMI 2.0 3D: TnB, SbS, F.P.
 Compression technology: JPEG2000 based on video compression algorithm without visual loss

Generals:

Dimensions: 123/147 mm (with fixing plate) width x 132 mm height x 40 mm depth.
 Weight: 370 g.

Specific Video Link 4K ENCODER

USB port: Type B USB2.0

Specific Video Link 4K DECODER

USB port: Type A USB2.0

Built-in output scaler

Selection of the flow received via IP from the keypad of channel 3 of Olympia 3 and a specific option in the Virtual CU application.



Configuration Software

Olympia 3 CU CONTROL application

The Olympia 3 CU will require a computer with the CU CONTROL software application enabling output level adjustment, assistance and intercommunication with the commentators. Further, supervision of the commentary program generated and the signals available for commentator monitoring are also part of the functions provided by this software application. This software should be combined with the setup and configuration software applications:

Olympia 3 Setup

Configuration tool for the CU's of an Event: configuration of the different available headphone monitoring sources and line outputs of the equipment. Internal Routing of the local audio sources of the CU, fader bank and virtual switches for the configuration of the gain and I/O Routing of the unit.

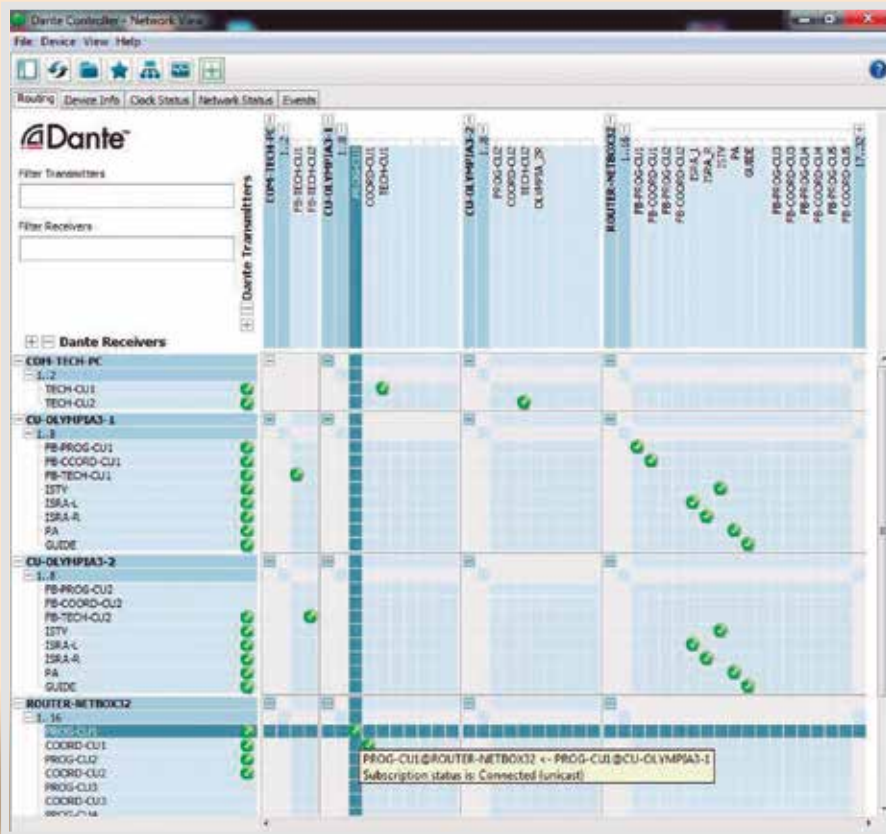

Dante™ Controller

Free software application from Audinate that allows routing the Inputs and Outputs of the CU in a system that is connected to the Dante™ AoIP multichannel Network together with other Dante™ enabled equipment. When the CU is connected to other Dante enabled products such as the AEQ NetBox, the Dante™ Controller allows for the manual “patching” and distribution of the signal.

Crossmapper

Whenever the CU is connected to an Intercom Matrix, the “Crossmapper” Software will be registering the Olympia 3 as a Series 8000 8-key Intercom User Panel. The Software “Crossmapper” is the configuration application for the Kroma by AEQ Intercom User Panels and allows us to configure local order and intercom keys.

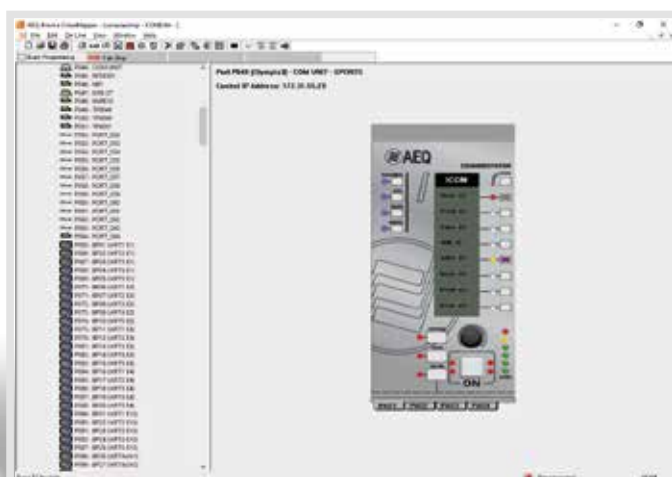

Olympia software applications

On demand, all Olympia operational capacity can be deployed: planner, Olympia Virtual CCU and other tools developed by AEQ for large and medium events.



Olympia 3 CU CONTROL specifics

This application allows us to have a real-time control of the CU. When opened, the screen adopts a similar aspect tot the CU control surface and includes the talkback system between the Commentary Control Operator and the commentators. It also provides VU-meters and the representation of the status LEDs of the CU.

The CU CONTROL is a remote control for the CU that effectively can be a parallel or simultaneous operation of the controls when inexperienced commentators so require.

The following operational screens have been implemented and are apt for touch-screen operations.

Individual CU control:

Individual screen: Intuitively adjusting partially to the placement of controls on the surface, the functions and controls in the view (including faders and channel and master Vu-meters) as well as some hidden ones like the Aux In (2 Mono or 1 ST), Oscillator and Identifier, and local outputs with their levels. It incorporates dynamic and equalization handling sub-screens (modification and activation).

At the top of the screen are represented the main output circuits, PROGRAM and COORDINATION, with a set of keys with the basic functions: Circuit activation, tone output, ID output, Vu-meter, Precision Vu-meter, international sound mix and auxiliary input mix. On the left side of the screen is a list of calls from unanswered users.

In the center you can see the channels of the three commentators. For each channel:

- In a representation of the display we can see labels of the signals available for monitoring, their levels and indications weather monitored on right, left or both earphones.
- On the right is the output fader for each channel and the Vu-meter showing the post-fader output level.
- At the bottom there is a replica of the commentator keyboard for each channel and that provides the possibility to correct operational errors or settings.



Screen of all CUs:

Idle scren in wich are the basic parameters of an amount unlimited of CU to control (about 20 at a time and more with scroll).

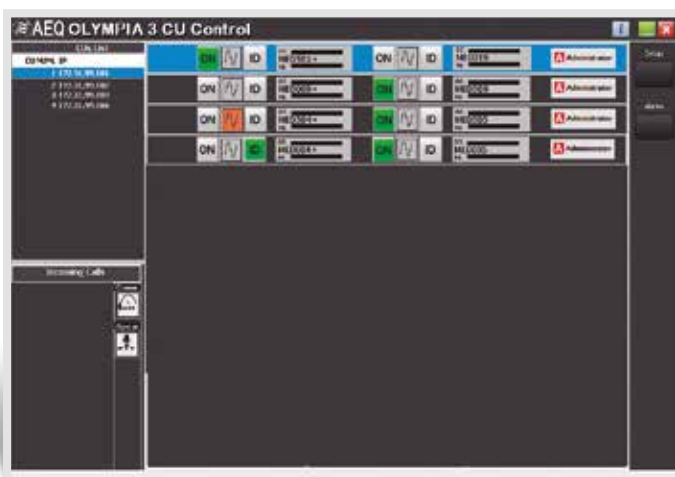

Auxiliar screen - "Monitoring all":

This screen will show and queues all internal Intercom calls of the Commentator System that remain pending to attend.

Auxiliar screen for Eq. and dynamics

On this screen it is possible to control and adjust levels, create and activate presets for the audio processing of the audio inputs: filters, parametric equalisation, compressor - limiter – expander and noise gate.



OLYMPIA 3

Digital audio technology with 48kHz sampling frequency and 24 bits resolution.
Internal summing and distributing matrix for all inputs and outputs.
Digital gain adjustment for all inputs, outputs and crosspoints. Range: $-\infty$ to +24 dB.

Microphone inputs

- 3 x XLR-3 female inputs.
- 48V Phantom power supply.
- Input impedance: $> 2\text{ K } \Omega$.
- Electronically balanced preamplifier with digital gain control in 1 dB steps.
- Nominal gain set to 62 dB (-58 dBu input is required to obtain a nominal -20 dBFS level).
- Preamplifier analog gain range: -36 dB to +19 dB referred to the nominal setting.
- Digital input gain range: $-\infty$ to +24 dB.
- Equivalent input noise: -126 dBu. @ 200 Ω source.
- Bandwidth: 20 to 20,000 Hz @ +/- 0.5 dB.
- THD+N: $< 0.02\%$ @ 20 to 20,000Hz, -40 dBu.
- Maximum input level: -2 dBu.

Line inputs

- 2 x XLR-3 female inputs.
- Electronic balancing.
- Input impedance: $> 20\text{ Kohms}$.
- Maximum input level: 24 dBu.
- Nominal level: +4 dBu (-20 dBFS).
- Noise: -83 dBu.
- Distortion: $< 0.005\%$ @ 20 to 20,000 Hz.
- Bandwidth: 20 to 20,000Hz @ +/- 0.5 dB.
- Digital gain adjustment range: $-\infty$ to +24 dB.

Input audio processing

- Low pass filter with adjustable crossover frequency between 1 kHz and 20 kHz.
- High pass filter with adjustable crossover frequency between 20 Hz and 1 kHz.
- 3-band parametric equalizer. Center frequency (10 Hz to 20 kHz), quality factor Q (0.1 to 20) and Gain (+/- 18 dB) can be adjusted independently for each band.
- Compressor-Limiter-Expander. Up to 5 zones can be defined. Threshold (-40 dB to +22dB), attack time (0.5 ms to 100 ms), release time (10 ms to 10 s), compression rate (1:50 to 1) and gain (0 dB to +40 dB) can be adjusted independently for each zone.
- Noise gate: with adjustments for threshold (-72 dB to 0 dB), attack time (0.05 to 100 ms), release time (0.5 ms to 10 s), hold time (0.05 ms to 2 s) and range (0 dB to 90 dB).

Headphone outputs

- 3 x Stereo 1/4" Jack outputs.
- Allowed load impedance: $> 16\text{ } \Omega$.
- Maximum output level: +6,4 dBu.
- Bandwidth: 20 to 20,000 Hz @ +/- 0,5 dB, 300 Ω .
- Distortion : $< 0.05\%$ @ 0 dBu, 20 to 20,000 Hz, 300 Ω .
- Digital gain adjustment range: $-\infty$ to +24 dB.

Line outputs

- 2 x XLR-3 male outputs.
- Electronic balancing.

- Output impedance: $< 20\text{ } \Omega$.
- Maximum output level: 24 dBu.
- Nominal level: +4 dBu (-20 dBFS).
- Noise: -88 dBu.
- Distortion: $< 0.005\%$ @ 20 to 20,000 Hz.
- Bandwidth: 20 – 20,000 Hz @ +/- 0.5 dB.
- Digital gain adjustment range: $-\infty$ to +24 dB.

AoIP Inputs and outputs

- 8 configurable channels. Dante™ Protocol, compatible with AES 67. Allows for redundant installation.
- Data format: DANTE™ Audio-over-IP technology, featuring:
 - Plug & Play technology.
 - Precise, sample-accurate, playback synchronization, even with several switch hops.
 - Extremely low and deterministic delay across the whole network.
 - Scalable and flexible network topology supporting a large number of audio transmitters and receivers.
 - Operates in a single integrated network for audio, video, control and monitoring. Compatible with other kinds of traffic when QoS is managed.
 - Supports 100 Mbps, 1 Gbps and 10 Gbps network links.
 - Uses low cost, "off-the-shelf" network equipment.
 - Resolution 24-bit, 48 kHz sampling rate.
 - Latency: 1 - 2 ms. (@ 48 kHz, typical, depends on network quality and complexity).
 - Binary rates: 100 Mbps/1 Gbps.
 - Maximum cable length between devices or to the switch: 100 meters with CAT5e or better wiring. Use optical fiber links for longer hops.

Communications interfaces

- Internal Ethernet Switch with 3 external 1Gbps/100 Mbps ports with RJ45 connectors. One of these ports supports PoE+ power supply. Firmware and configuration protection for unused ports in order to avoid unauthorized system access through them.

Other features

- Standard test signals (tone and pink noise).
- 2 x line identifier recordings.
- External delay and CU linking when used in combination with BC 2000D and Conexia routers.
- Replay of the latest message received by Intercom.

Physical specifications

- Front panel interface with keyboard, LED signaling, rotary menu navigation encoder, 3 OLED graphic displays and 3 LED vu-meters.
- Operating temperature: 10 to +45 °C (14 to 114 ° F).
- Dimensions (W x D x H): 302 x 270 x 100 mm. (11 57/8 x 3 15/16 in).
- Weight: 2,500 gr. (5lb, 8.2 oz).
- Redundant 48VDC power supply. Power consumption: 15W max. PoE+ and external 90-263V 50/60 Hz adapter input.

From the most basic to the most complex

Operating as: A standalone CU, Connected to an AoIP multichannel network, connected to an AoIP Intercom Matrix or to a large Commentary System with a Routing Matrix.

A basic feature of the Olympia 3 is that it admits scalable operation: Standalone, connected to a Dante™ network, associated to KROMA by AEQ Intercom matrices or to BC 2000D, offering the same full functionality that can be found in the Olympia Commentary Systems.

Olympia 3 allows for operation in all possible scenarios where a Commentary Unit is required; from the basic ones with limited budget, to the most complex ones in terms of required services. At the same time Olympia 3 is especially suitable for mid sized events where they can share infrastructure with an Intercom matrix within a Venue or Mobile Unit.

Apart from operating as a Standalone CU (portable mixer) with local I/Os, this CU can connect to remote equipment of different levels and types:

- Connected to any Dante™ / AES67 enabled equipment such as for example network interfaces and routed manually with the Dante™ Controller.
- Connected to an Intercom Matrix such as the AEQ CrossNET, with up to 160 x 160 AoIP channels and 12 analogue I/Os can service between 12 and 16 CUs depending on the number of remote and common signals required.
- In combination with an Intercom Matrix such as the AEQ ConeXia, with almost "infinite" I/Os and as an extension to an Intercom System.
- Customized Host Broadcaster Commentary System connected through as high performance Routing Matrix such as the AEQ X_Core/Olympia.

COMMENTARY UNITS IN "STANDALONE" CONFIGURATION: Audio is connected locally and the unit is controlled through a computer.

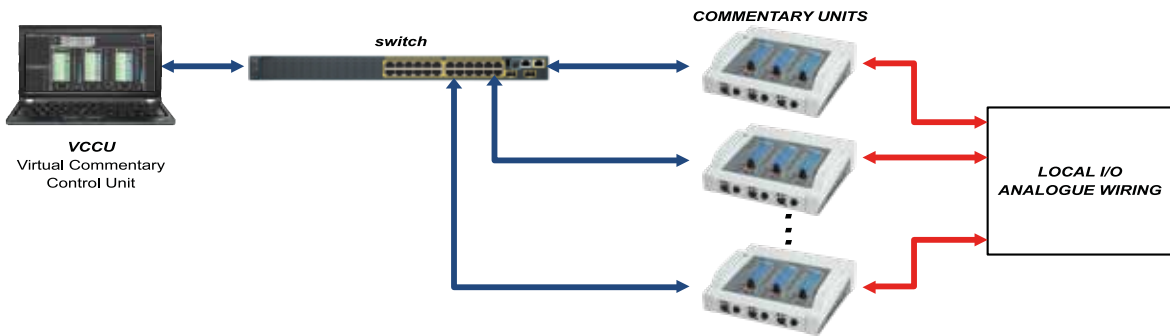

COMMENTARY UNITS AS AN INTEGRATED PART OF THE KROMA by AEQ INTERCOM SYSTEM ROUTING MATRIX: CU's are controlled through a computer. Audio is connected to the router and is routed with the DANTE™ Controller. Channel 1 can be operated as an Intercom User Panel and at any moment during operation.

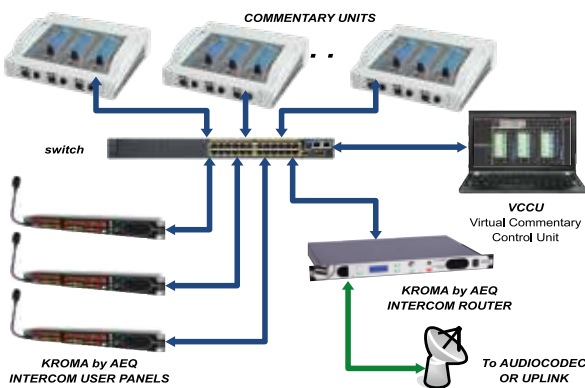

COMMENTARY UNITS CONNECTED TO AN AUDIO CONSOLE OR INTERFACE WITH DANTE™ AoIP NETWORKING CAPABILITIES: Audio is connected via the DANTE™ AoIP Multichannel Network and is routed with the DANTE™ Controller. The CU's are controlled through a computer.

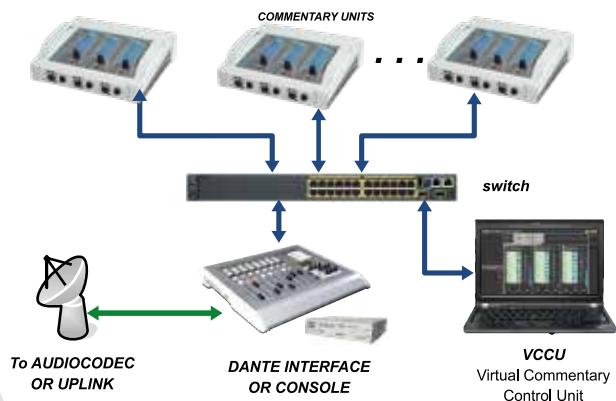

COMMENTARY UNITS CONNECTED TO A LARGE CAPACITY ROUTING MATRIX IN A LARGE COMMENTARY SYSTEM FROM AEQ: The control of both system and CU's is through a Group of computers. The Audio is linked to the AEQ routing matrix via the DANTE™ AoIP Multichannel Network. The System is redundant in regards to Audio, Control and Power. The IP network can also provide auxiliary connectivity for supplementary services such as IP video and additional data services.

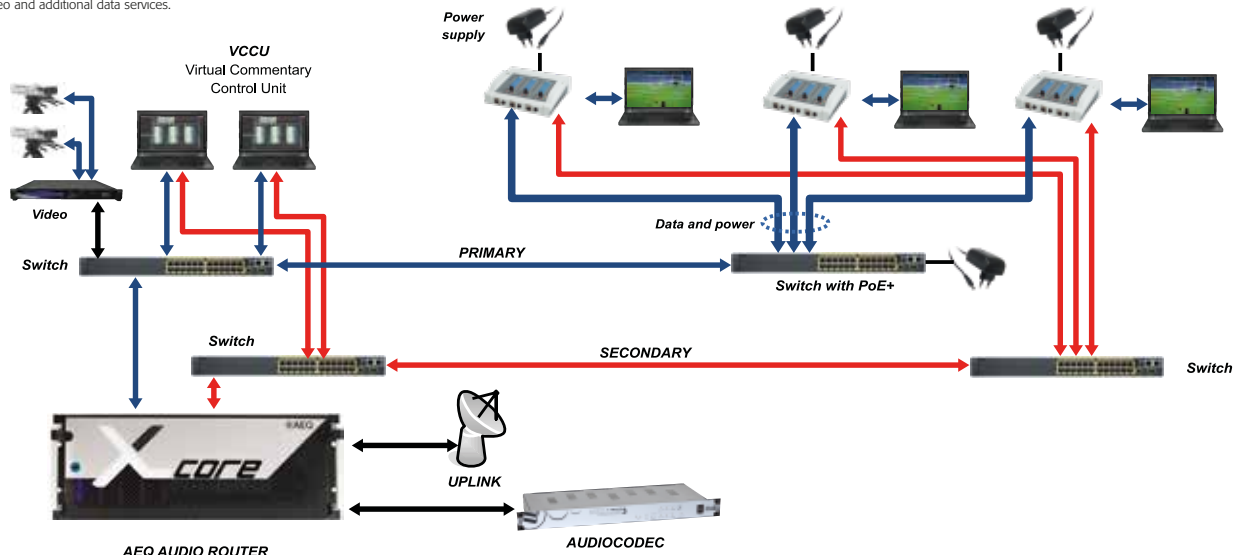



Examples of deployment and operation of the AEQ Olympia 3 Commentary System at a multi-venue event



Olympia 3 at the Olympic Stadium in Berlin, Germany.

Deployment and operation of the AEQ Olympia 3 Commentary System at a multi-venue event.

Next, the description of part of a system used in a real sports event is provided.

A system with more than 75 IP commentary positions has been designed and deployed at multiple venues separated by considerable distance. The subsystem comprising 12 sports venues equipped with OLYMPIA 3 commentary units, the audio router in the IBC (International Broadcasting Center (IBC)), the intercom system and transport infrastructure to the affiliated broadcasters (all this using Audio over IP) is described.

The trunk infrastructure consists in an Audio Routing Matrix X_Core with capacity for 512 x 512 channels. Monitoring and real-time operation is performed using the BC2000D RTC control software application, while the static routing infrastructure has been established with Dante Controller. This logical architecture using several layers of superimposed routing, together with the use of the AEQ Audiocodex Venus 3 with Dante connectivity, has allowed the system to be flexibly expanded in real time, establishing additional routes, even international, allowing to cover the needs of circuits shortly before the start of the event.

Audio transport between all the venues and centralization of the IBC has been deployed over an AoIP network with Dante's redundancy logic.

The commentator system at each venue, depicted at the left, was implemented by connecting redundant AoIP Dante OLYMPIA 3 commentator units to a TOC (Technical Operations Centre for audio monitoring and control systems) built around the AEQ NETBOX 8 and NETBOX 32 AoIP interfaces. Control was performed using the control application for the OLYMPIA 3 Commentary Units.

For mixed zones where journalists interview athletes, AEQ NETBOX 4 MH AoIP interfaces were installed, providing the necessary microphone inputs and headphone outputs.

For further information, please follow this link: "Application Note Olympia 3 at a multivenue event": <http://www.aeq.eu/products/olympia-3>.



Examples of deployment and operation of the AEQ Olympia 3 Commentary System at a multi-venue event

MULTI-VENUE, IP CONNECTED SPORTS SYSTEM

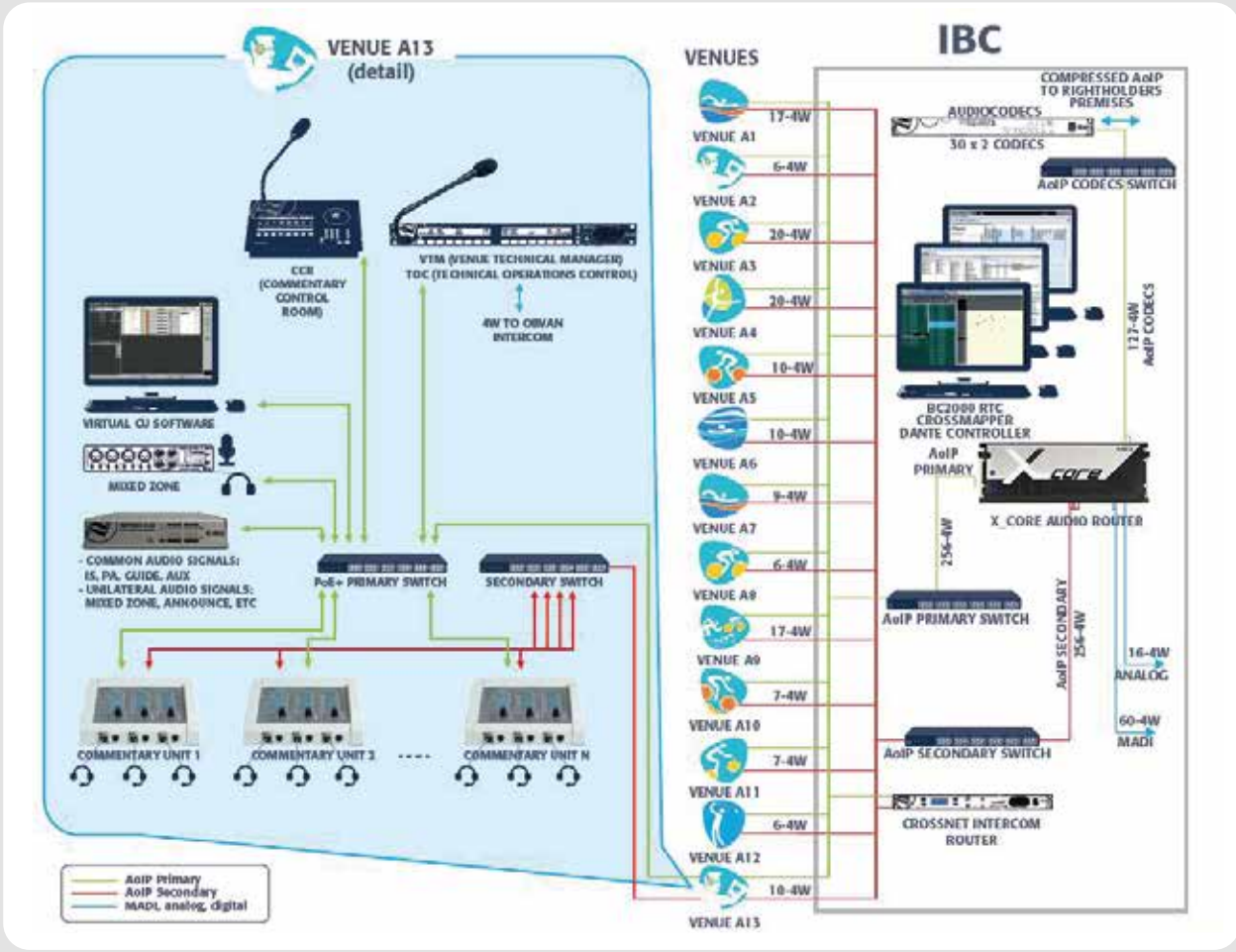

CCR with CCU (Commentary Control Unit) at the Olympic Stadium in Berlin during the 2018 European Championships.



Commentators on duty at the Olympic Stadium during the 2018 European Championships.



More than 30 years of experience with audio at Sports Events

AEQ - SPAIN (HQ)

Margarita Salas, 24
28919 Leganés · Madrid · Spain
Tel.: +34 91 686 13 00
Fax: +34 91 686 44 92
website: www.aeq.eu
e-mail: aeqsales@aeq.es

AEQ - CATALUNYA

Tel.: +34 93 414 03 96
e-mail: nolivella@aeq.es

AEQ - PORTUGAL

Tel.: +35 1 261 101 874
e-mail: apicarra@aeq.es

AEQ - INDIA

Tel.: +91 987 363 32 11
e-mail: nirav@aeq.es

AEQ - KROMA MEXICO

Tel.: +55 54132716
e-mail: creyna@aeq.es

AEQ - USA

Tel.: +1 (954) 581 79 99
e-mail: sales@aeqbroadcast.com