

RMx4™ / RemoteMix x4™

4 Channel Field Mixer



FEATURES

- » Four Low Noise, High Headroom, XLR mic inputs (Mic/Line Switches on Channels 3 & 4)
- » Individually Switchable 48v Phantom Power
- » 120 Hz Low Cut Filter
- » Master XLR Output 20 Hz – 20 kHz
- » Four ¼" Headphone Jacks with Individual Source Selector and Level Controls
- » ¼" Headphone Cue Input
- » Phone Headset Interface with 3.5 mm TRRS plug
- » 3.5 mm Stereo Line Input
- » 3.5 mm Send and Receive Jacks
- » LED VU Meter
- » Hot Swappable Dual 9V Batteries and 120-240 VAC External Power Supply
- » Made in America
- » Compliance tested for North America, CE Markets, and Australia

Mix It Up. RMx4 combines a four-channel field mixer with a four-channel headphone amplifier. After all, what good is a field mixer if you don't have a flexible monitoring capability for the whole crew?

Great Sound. A soft limiter prevents overdriving the full-duplex headset interface, while the master XLR and 3.5 mm outputs are pre-limiter (full range). Line level cue input to the headphones make RMx4 a perfect companion to your codec or recorder.

Convenient. 3.5 mm send and receive jacks for recording or playing back recorded material. Separate headphone level and source selection controls for each headphone output. Monitor just the clean mixer output, or the Cue input plus the mix.

Power Smart Design. Switchable 48V Phantom Power on each mic input. Powered by 1 or 2 hot-swappable 9V batteries that automatically kick in if AC power goes down. Low noise, low power ICs are used throughout to preserve battery life. The 100-240 VAC desktop style power supply (included) overrides the battery power only when the supply is actually providing power.

Radio. RMx4 is designed for news and sports remotes. Use it as a front-end mixer for your POTS, ISDN, IP or smart phone codec. XLR out, ¼" return to headphones.

TV. RMx4 is designed for ENG, Sports, and interviews, with four ¼" headphone outputs. 3.5 mm TRRS provides 2-way IFB audio from your cell phone or notebook.

RMx4™ / RemoteMix x4™

4 Channel Field Mixer

REAR VIEW

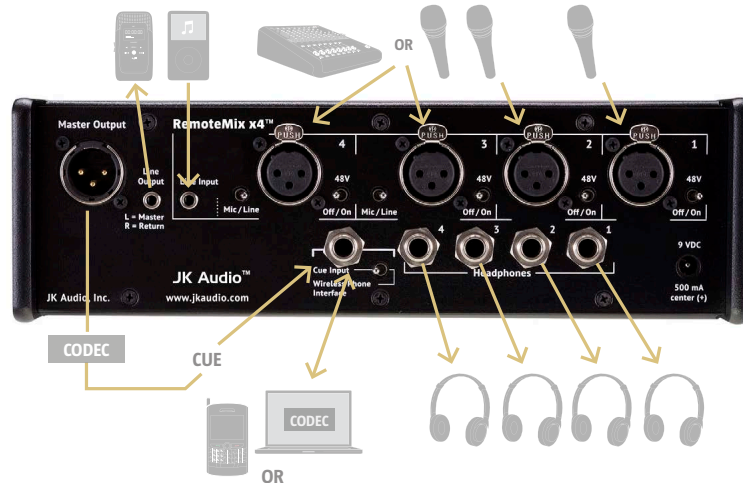

BLOCK DIAGRAM

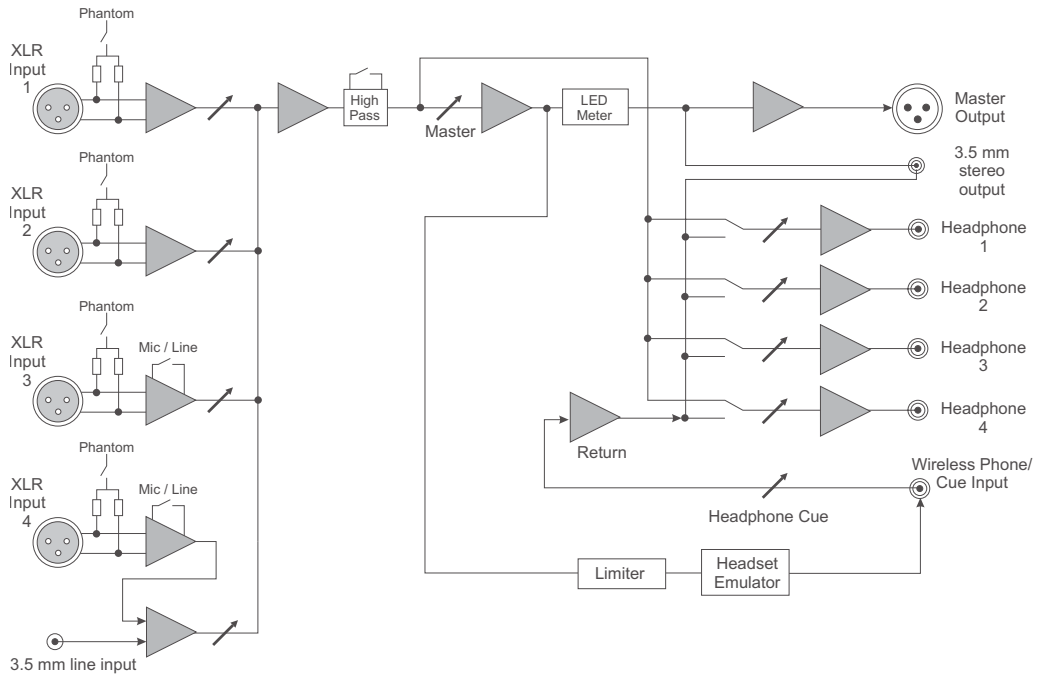

SPECIFICATIONS



Input

Female XLR Mics (4):	2k ohms / -25 dBu nom Channel 3 & 4 have -40 dB Mic/Line pad switch Line = 50k ohms / +20 dBu max
Phantom Power:	48 VDC with 6.8k ohm supply resistance
1/8" (3.5mm) Stereo Line:	20k ohms / -10 dBu nom
1/4" Headphone Cue:	20k ohms / -10 dBu nom

Misc

Power:	100-240 VAC, 50-60Hz external power supply or Two 9 VDC batteries
Size:	9.5" x 8" x 3"
Weight:	3.6 lbs (1.6kg)

Output

Balanced Male XLR:	50 ohms / +16 dBu max 20 Hz - 20 kHz +/- 1dB 0.04% THD @ +16 dBu
1/8" (3.5mm) Stereo:	100 ohms / -10 dBu nom
Headphone 1/4" Stereo:	8 ohms / 1/3 watt per channel