

MULTISTANDARD MULTIMODE DIGITAL & ANALOG TERRESTRIAL TV TRANSMITTER LINE - COMPACT SERIES

The high quality, professional and cost-effective solution

10, 25, 50, 100, 200, 250, 500, 1000W
COMPACT TV TRANSMITTER - TRANSPOSER

FEATURES:

- A high performance digital & analog Multistandard Multimode TV Transmitter Line featuring latest technology
- High reliability and extremely compact size
- Low power consumption
- Low cost of ownership, low capital cost, running expenses & maintenance

ANALOG

DVB-T/H

DVB-T2

ISDB-T/Tb

ATSC

DVB
Digital Video
Broadcasting



ABE Elettronica is proud to present the “MTX” Compact Series of Transmitters – Transposers - Gap-fillers for Analog and Digital Terrestrial Television Broadcasting (DVB-T/H, DVB-T2, ISDB-T/Tb, ATSC and other standards).

With the company’s 30 years of experience in this field, the “MTX” Series is the ultimate in technology, quality and performance; it is designed to take ad-

vantage of the excellence of the digital modulation systems to generate both Analog and Digital emissions.

This new “MTX” Compact Series of Transmitters – Transposers - Gap-fillers brings together the highly efficient and reliable ABE MOS and LD-MOS broadband Power Amplifiers with state-of-the-art technological solutions.



The Compact MTX Transmitter/Transposer Series is a professional product line, suitable for the integration in both analog and digital TV transmission networks (DVB-T/H, DVB-T2, ISDB-T/Tb and others operating both MFN and SFN).

The equipment is fully contained in a single 19" rack drawer and is capable, with its internal RF power amplifier, to provide up to 500Wavg digital output or 1,000Wp.s. in analog mode.

Featuring a modular construction – with easily replaceable boards and parts - the MTX exploits the advantages of latest components and mounting technologies to achieve high-reliability and comprehensive system flexibility – all in a reduced footprint.

Maintenance, control as well as parameter changes and settings, are simple and easy-to-perform operations.

The equipment can be equipped with one or more digital processor boards according to the calculation and processing capacity requested by the TV standard/s implemented in the transmitter / transposer.

For example, if the unit is used for **analog multistandard** TV emission (B,G,D,H,I,K,K1,M,N standard) or for one of the first generation digital TV standards (e.g.: DVB-T/H, ISDB-T...) just one digital processor board is enough.

The digital processor board can store one or more different TV standards without any firmware upgrade.

If optional functions are needed (like re-multiplexing, seamless switching and others) it is necessary to equip the unit with two digital processor boards. For the DVB-T2 TV standard are necessary three digital processor boards.

A key function of the equipment is the digital linear and non-linear pre-correction with the possibility to store and recall up to 8 different pre settings. The **linear pre-correction** changes the amplitude and group delay versus the frequency to prevent distortion mainly introduced by the output filter of the transmitter. The **non-linear pre-correction** introduces a pre-distortion in the amplitude and phase based on the level required to correct the non-linearity mainly introduced by the power amplifier, therefore giving the opportunity to increase the output power, MER & shoulder performance.

Optionally, for digital modulations, it's possible to equip the MTX Compact Transmitter with the **adaptive non-linear pre-correction** module which automatically provides the linearization.

The transmitter can manage up to 4 inputs with "near-seamless" or, optionally, "seamless" automatic switching.

Several interface types are available for different configurations:

- **ADC** (Analog to Digital Converter) for Video and Audio analog inputs (for analog modulation standards)
- **ASI** (Asynchronous Serial Interface)
- **Ethernet** (T.S. over IP) able to receive MPEG transport streams (encapsulation ProMpeg COP#3 rel.2)
- **DVB-S/S2** receiver for reception from satellite or from a radio-link transmitter and for configuration as trans-modulator or gap-filler. (The receiver can optionally support **multistream** and **PL de-scrambling**)
- **DVB-T/H** terrestrial reception for configuration as a regenerative repeater

The MTX can optionally be equipped with a **CAM (Conditional Access Module)** to decrypt encoded Transport Streams (i.e. from the DVB-S/S2 satellite receiver).



The optional digital processor can also provide **re-multiplexing functions** (with PID filtering, insertion / change of tables, etc.) and "**seamless**" switching between two transport stream inputs; in this way, when operating in SFN mode, the transmitter doesn't interrupt the emission when switches between input transport streams (from primary to secondary or vice versa).

The transmitter is equipped with a **direct digital synthesis modulator** with the possibility to select any output frequency in the operating frequency range with 1Hz resolution.

The **GPS receiver** option, specifically developed for the timing function, provides time and frequency signals (1PPS and 10MHz) necessary for the synchronization of the transmitter when operating in **SFN Mode**. This is a new concept Timing Reference GPS Locked generator with unique special features, with proprietary algorithms, to prevent network de-synchronization (Holdover error recovery, Single satellite operation, Fast cold start-up, Zero cumulated error, etc.) and is available in redundant configuration (double radio). Moreover, the reference high-stability "oven type" oscillator employed is capable of maintaining the synchronization over long periods when there is an intermittent signal from the GPS satellites (**holdover function**). In analog transmission mode, with the GPS receiver option, the equipment can also operate in "**precision offset**" mode, to reduce co-channel interference.

The wide-band and high-efficiency (low power consumption compared with the output power) Power Amplifier employs the latest generation of **MOS** and **LD-MOS** semi-conductors that feature a very linear amplification characteristic further enhanced by the modulator's digital non-linear pre-corrector. The RF output Power Amplifier operates in a redundant configuration.

The efficiency of the transmitter is further improved by the use of Switched-Mode power supplies equipped with **PFC, Power Factor (cos φ) Corrector**, in order to minimize reactive power consumption.

The MTX transmitter/transposer can operate in redundant configuration (**1+1 and/or N+1**) by means of an external change-over unit.

Additional features of the "MTX" Series transmitters also include:

- Comprehensive monitoring and protection circuits, including a Power Amplifier fold-back function to reduce output power before tripping off, due to high VSWR, heat-sink over-temperature or over-drive
- **Soft Start** function to avoid output power surges
- **ALC** (Automatic Level Control) to stabilize the Power Amplifier's RF output level over a limited range.

The innovative management and control board of the equipment is built around a 32 bit micro-controller with the following key characteristics:

- **Local Control** from the front panel, easy and friendly, with LCD graphic display LCD and keypad
- **LAN Interface** (Ethernet Base T 10/100 – RJ45 connector) in addition to RS485

- **Web Server** with access protected by username/password (3 different levels of control) able to read/set all the equipment parameters
- **Event Logger** (recording with date & time of all events of alarms, power-on, fault conditions etc.) with storage of more than 5,000 events and is downloadable through the transmitter's WEB Server
- **Remote Upgrade Function** for the control board firmware
- **Email Client** for the automated notification, via email to pre-programmed addresses, of changes in alarm conditions
- **SNMP Agent** able to send alarms ("traps"), to read equipment parameters (through the "get" command), to set the equipment (i.e. reset through the "set" command)

The connection between the transmitter's LAN interface and the control centre can be established by means of a GPRS or UMTS modem / router, a radio data -link or an ADSL or PSTN modem.



"MTX" SERIES: TAKE ADVANTAGE OF ANALOG TV TRANSMITTERS WITH DIGITAL PROCESSING

- Improved performance as digital processing introduces less noise and distortion and does not require any adjustment, calibration or re-calibration
- Several additional features and many more possibilities (e.g. built-in video test generator, linear and non-linear digital pre-correction, flexibility in modifying and correcting input and output signals, etc.)
- The same hardware to switch to digital modes, thus having a truly "digital ready" transmitter
- Greater ease of on-site upgrade

Standard configuration Technical Specifications

MTX D10- 25-50-100-250-500 (Digital operation only)

MTX A10-25-50-100-200-250-500-1K0 (Analog versions with option for digital operation)

Output Power (tol.+0/-1dB - analog 4 cavities or digital 6 cavities output filter loss included):	MTX A25 - MTX D10 (1U rack drawer): 25Wp.s. (analog operation - MTX A only) - 10Wawg (digital operation) UHF MTX A50 - MTX D10 (3U rack drawer): 50Wp.s. (analog operation - MTX A only) - 10Wawg (digital operation) UHF MTX A50 - MTX D25 (1U rack drawer): 50Wp.s. (analog operation - MTX A only) - 25Wawg (digital operation) UHF MTX A100 - MTX D25 (3U rack drawer): 100Wp.s. (analog operation - MTX A only) - 25Wawg (digital operation) UHF MTX A200 - MTX D50 (3U rack drawer): 200Wp.s. (analog operation - MTX A only) - 50Wawg (digital operation) UHF MTX A250 - MTX D100 (3U rack drawer): 250Wp.s. (analog operation - MTX A only) - 100Wawg (digital operation) UHF or VHF B.III MTX A500 - MTX D200 (5U rack drawer): 500Wp.s. (analog operation - MTX A only) - 200Wawg (digital operation) VHF B.III MTX A500 - MTX D250 (5U rack drawer): 500Wp.s. (analog operation - MTX A only) - 250Wawg (digital operation) UHF MTX A1K0 (5U rack drawer): 1KWp.s. (analog operation - MTX A only) - 400Wawg (digital operation) UHF or VHF B.III MTX D500 (5U rack drawer): 500Wawg (digital operation) UHF or VHF B.III
Output Frequency range:	UHF (470 to 862MHz) or VHF BIII (175 to 230MHz)t
Output Impedance and connector:	50Ω type "N" Female (up to 250Wp.s./100Wawg) and "7-16" Female (for higher power)
Spurious, harmonics and out of channel IMD:	≤ -60dB (with RF output filter)
Output frequency stability: (with high stability reference oscillator)	±500Hz (aging: ≤ 100Hz/month – after 6 months operation) Option: ±100Hz or higher stabilities, including GPS locked reference oscillator
GPS Locked reference oscillator option:	GPS Receiver: 12 channels; Input TNC female 50Ω; Sensitivity: -154dBm; 1pps rms accuracy: 30nS; Power supply (for amplified antenna): +5V (excludible); 10MHz oven oscillator option aging: 1•10-9/day or 2•10-10/day

DIGITAL OPERATION SPECIFICATIONS

Transmission standard:	OFDM (DVB-T/H; DVB-T2; ISDB-T/Tb); 8VSB (ATSC); other on request for detailed specifications see driver specific documentation
Intermodulation products (shoulders) just outside channel edges (before output filter):	According to the model and power output (typ. Spec. $\leq 38\text{dB}$ with reference to emission channel centre power density)
MER – Modulation Error Ratio:	According to the model and power output (typ. Spec. $\geq 35\text{dB}$)
Input interface options:	ASI; Ethernet (T.S. over IP); DVB-S/S2 multistream receiver; terrestrial receiver (for different input interfaces and specifications, see driver specific documentation)

ANALOG OPERATION SPECIFICATIONS

Transmission standard:	B, G, D, H, I, K, K1, M or N
In band intermodulation products	$\leq -60\text{dB}$ (typical; max. -56dB – Test: V.C. -8dB ; S.C. -10dB ; C.S. -16dB)
Video input:	1Vpp (75 Ω BNC-f) – video processing include ALC and signal reconstruction
Transmitted Video quality parameters:	Differential gain: within $\pm 1.5\%$ (typical; max. $\pm 5\%$); Differential phase: $\pm 1.5^\circ$ (typical; max. $\pm 3^\circ$) 2T K rating: 1% (typical; max 2%); Random noise (weighted typical): $\geq 60\text{dB}$; Group delay response (V.C. to C.S.): Within $\pm 40\text{nS}$ Amplitude / frequency response: (V.C. to C.S.): Within $\pm 0.5\text{dB}$ (typical; max. $\pm 1\text{dB}$)
Audio input:	0dBm (adjustable) 600 Ω bal. / unbal.
Audio options:	Stereo / dual sound IRT; BTSC; other on request
Transmitted Audio quality parameters:	Amplitude / frequency response: $\pm 0.5\text{dB}$ (typical; max. $\pm 1\text{dB}$); Harmonic distortion: $\leq 0.4\%$

GENERAL SPECIFICATIONS

Power supply:	According to the model: 90 to 264 Vac single phase or 207 to 415 three phases 50/60Hz
Remote control interface options:	RS485; Ethernet 10/100 Base-T (SNMP - web server - e-mail client) Remote firmware upgrade: supported
Housing:	Standard rack 19" 1U or 3U or 5U according to the model - rack cabinet available as option
Operating temperature range:	-5 to $+45^\circ\text{C}$
Maximum operative humidity:	90% non condensing

MTX Transmitter-Transposer block diagram

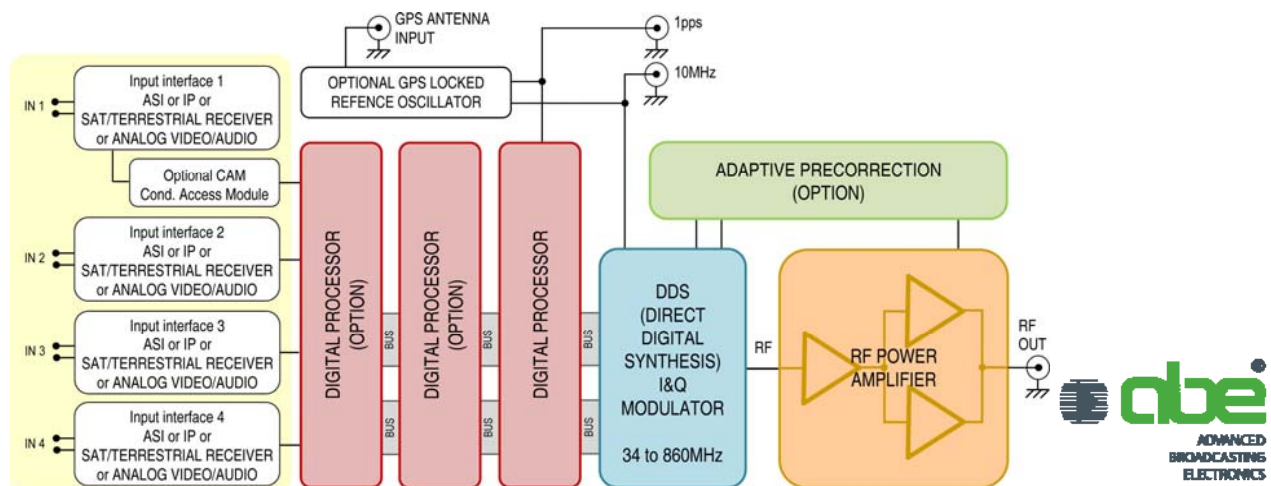

All specifications contained in this document may be changed without prior notice.